



## **TP300 / TP350**

EXCLUSIVELY BY RAYNOR GROUP COMPANIES

ASSEMBLY INSTRUCTIONS  
OPERATING INSTRUCTIONS  
WARRANTY

---



---



CUSTOMER SERVICE 1-800-637-0005  
[WWW.RAYNORGROUP.COM](http://WWW.RAYNORGROUP.COM)

# ASSEMBLY INSTRUCTIONS

TP300 / TP350

Remove all items from the carton. Verify all pieces before assembly.

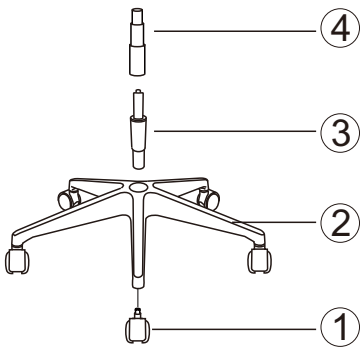
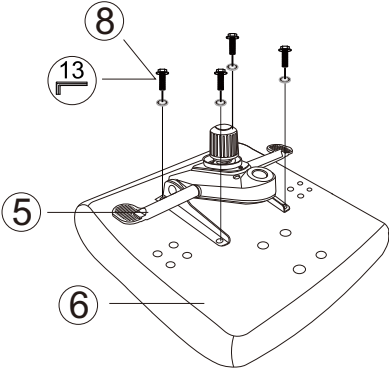
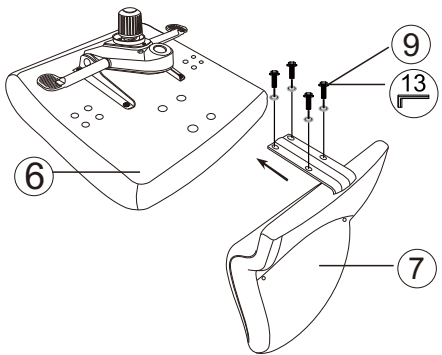
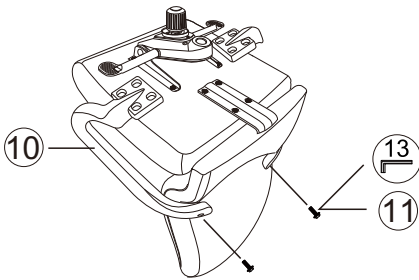
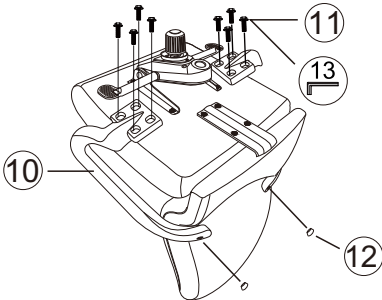
KEY QTY DESCRIPTION			KEY QTY DESCRIPTION			KEY QTY DESCRIPTION			
PARTS LIST	1	5 pcs	Caster	7	1 pc	Backrest	11	10 pcs	Armrest Screws (1/4"*1-1/4")
	2	1 pc	Base	8	4 pcs	Mechanism Screws and Washers (5/16"*1", Red)	12	2 pcs	Arm Screw Caps
	3	1 pc	Seat Post (cylinder)				9	4 pcs	Back attachment Screws and Washers (5/16"*1-1/4", Blue)
	4	1 pc	Seat Post Cover	10	2 pcs	Armrest			
	5	1 pc	Mechanism						
	6	1 pc	Seat						

<p><b>STEP 1</b></p>  <p>Press Casters (1) into holes of the Base (2). Insert Seat Post (3) and Seat Post Cover (4) into the center hole of the Base (2).</p>	<p><b>STEP 2</b></p>  <p>For easy assembly, place Seat (6) face down on a flat surface. Attach Mechanism (5) to Seat (6) using 4pcs Screws and 4pcs Washers (8). Tighten securely with enclosed Allen Wrench (13).</p>	<p><b>STEP 3</b></p>  <p>Attach Backrest (7) to the Seat (6) using 4pcs Screws and 4pcs Washers (9). Tighten securely with enclosed Allen Wrench (13).</p>
<p><b>STEP 4</b></p>  <p>Insert 2pcs Screws (11) into the rear holes of Armrest (10) as shown, attaching Armrest (10) to Backrest first. Do not fully tighten these 2 screws until told to in Step 5.</p>	<p><b>STEP 5</b></p>  <p>Attach Armrest (10) to Seat using 8pcs Screws (11) as shown. Tighten securely with enclosed Allen Wrench (13). Now fully tighten the 2 screws (11) from Step 4 into the Backrest. Attach 2pcs Arm Screw Caps (12) to cover exposed holes on Armrest (10).</p>	<p><b>STEP 6</b></p>  <p>Turn assembled seat upright and locate center hole of Mechanism over Seat Post. Push down firmly until connection is secure. Before using your chair, ensure that all the screws are tightened fully for safety. You can now enjoy the comfort of your new chair! NOTE: Please keep the enclosed Allen Wrench and check all screws every six months to ensure they remain tightly fastened.</p>

## PREVENTIVE MAINTENANCE AND WARNING!

- USE THIS PRODUCT ONLY FOR SEATING ONE PERSON AT A TIME.
- DO NOT USE THIS CHAIR AS A STEP STOOL / LADDER.
- DO NOT SIT ON ANY PART OF THE CHAIR EXCEPT THE SEAT.
- DO NOT USE CHAIR ON UNEVEN FLOOR SURFACES.
- DO NOT USE CHAIR UNLESS ALL BOLTS, SCREWS AND KNOBS ARE TIGHTENED.
- EVERY SIX MONTHS, PLEASE MAKE SURE ALL BOLTS, SCREWS AND KNOBS ARE FULLY TIGHTENED TO ENSURE STABILITY.
- IF ANY PARTS ARE MISSING, BROKEN, DAMAGED OR WORN, STOP USE OF THE PRODUCT UNTIL REPAIRS ARE MADE USING FACTORY AUTHORIZED PARTS.
- DISPOSE OF PACKAGING PROPERLY. PLASTIC BAG IS NOT A TOY. DO NOT USE PLASTIC BAG AS HEAD COVERING – IT MAY CAUSE SUFFOCATION.
- FAILURE TO FOLLOW THESE WARNINGS COULD RESULT IN SERIOUS INJURY.
- NOTE: SOME SCREWS MAY BE PREASSEMBLED. IF PREASSEMBLED, IGNORE ASSEMBLY INSTRUCTIONS.

# OPERATING INSTRUCTIONS

TP300 / TP350

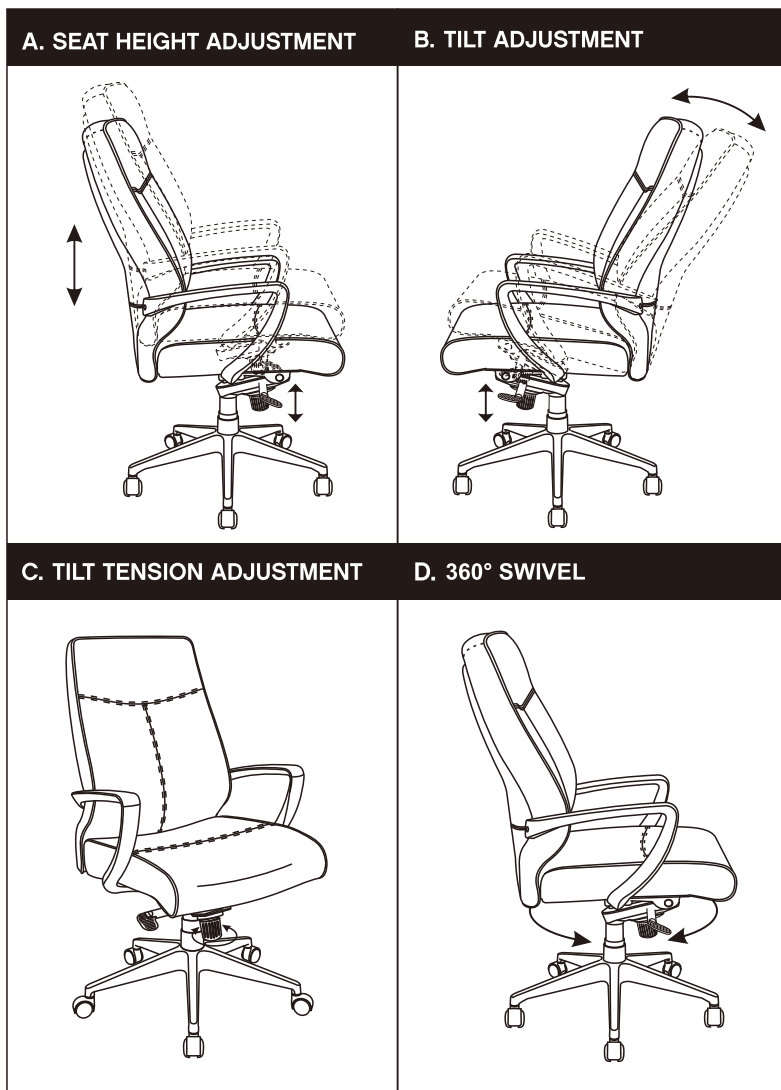

- A. SEAT HEIGHT ADJUSTMENT:**  
Pull lever up. Release lever when desired position is reached.
- B. TILT ADJUSTMENT:**  
Pull lever up and lean back to tilt. Push lever down to lock in desired position.
- C. TILT TENSION ADJUSTMENT:**  
Rotate knob clockwise/counterclockwise to adjust tilt tension based on body weight.
- D. 360° SWIVEL:**  
360° Seat swivel.

- USE THIS PRODUCT ONLY FOR SEATING ONE PERSON AT A TIME.
- DO NOT USE THIS CHAIR AS A STEP STOOL / LADDER.
- DO NOT SIT ON ANY PART OF THE CHAIR EXCEPT THE SEAT.
- DO NOT USE CHAIR ON UNEVEN FLOOR SURFACES.
- DO NOT USE CHAIR UNLESS ALL BOLTS, SCREWS AND KNOBS ARE TIGHTENED.
- **EVERY SIX MONTHS, PLEASE MAKE SURE ALL BOLTS, SCREWS AND KNOBS ARE FULLY TIGHTENED TO ENSURE STABILITY.**

## WARNING!

- IF ANY PARTS ARE MISSING, BROKEN, DAMAGED OR WORN, STOP USE OF THE PRODUCT UNTIL REPAIRS ARE MADE USING FACTORY AUTHORIZED PARTS.
- DISPOSE OF PACKAGING PROPERLY. PLASTIC BAG IS NOT A TOY. DO NOT USE PLASTIC BAG AS HEAD COVERING – IT MAY CAUSE SUFFOCATION.
- FAILURE TO FOLLOW THESE WARNINGS COULD RESULT IN SERIOUS INJURY.
- NOTE: SOME SCREWS MAY BE PREASSEMBLED. IF PREASSEMBLED, IGNORE ASSEMBLY INSTRUCTIONS.

# OUR PROMISE.

They say with age comes wisdom. And while we have learned a lot since we sold our first office chair in 1979, even then we knew that superior craftsmanship and design are essential ingredients in delivering real value for our customers. All these years later, those three simple pillars still stand behind our promise of exceptional seating with every chair we sell.

DESIGN CRAFTSMANSHIP VALUE

---

## RAYNOR GROUP COMPANIES WARRANTY

- Raynor Group ensures total customer satisfaction.
- Raynor Group warrants to the original purchaser all components for ten years, except for the upholstery which is guaranteed for five years.
- Raynor Group warrants to the original purchaser with proof of purchase that all parts will be free from defects in materials. Raynor Group will repair or replace, at its discretion, any unmodified component.
- Use of aftermarket hardware is not guaranteed.
- The warranty is limited to normal use no more than forty hours a week at a maximum weight of 250lb.
- The warranty is limited to replacement or repair and does not cover transport costs and labor.
- There are no other express or implied warranties other than those clearly described.
- Raynor Group shall not be liable for incidental or consequential damages resulting from any defect in the product.